

ROBOTIC ARCHITECTURE BASED ON ELECTRONIC BUSINESS MODELS

From Physics Components to Smart Services

José Vicente Berná-Martínez, Francisco Maciá-Pérez, Virgilio Gilart-Iglesias,
Diego Marcos-Jorequera

Computer Science Department, University of Alicante, San Vicente del Raspeig, Spain

Keywords: Robotic, Smart Services, SOA, e-Business, Distributed system, Middleware.

Abstract: This paper presents an approach for designing robots and robotic systems based on the application of models, architectures, techniques and tools that have contributed valid solutions in other areas, such as e-business. Before applying these solutions, the physical elements that make up a robotic system are subjected to a normalization process in order to characterize their functional contributions. In this way, the conceptual model and the technical architecture of the service-oriented architecture robotic system is established.

1 INTRODUCTION

Robotics is a continually growing area, and is subject to great barriers that condition its growth and functionality. Such obstacles include the lack of unicity and standards, even in the most elementary components; the complexity in its design, development and implementation due to the great number of implied disciplines; and the great dependency of the underlying technology that makes up and sustains the physical layer.

These types of problems, in which a multitude of actors, disciplines and technologies conjugate themselves, is very common in the development of applications distributed on the Internet and for which information and communication technologies (ICT) have already provided successful solutions. This new scene has forced the business applications to qualify mechanisms that allow their distributed development, reusability, integration of modules and components, and methods of interaction between organizations. Thus, models, architectures, design patterns and tools that are providing scalable, flexible, integrated and valid solutions, have been developed in the long term. In this way, the ICT, as a whole, have been instituted as the technological bases on which the present industrial and productive weave is sustained.

Due to the fact that the operative and functional requirements in the area of robotics coincide with

those that have been resolved in the area of internet-distributed applications, we propose applying these same solutions (n-tier architectures, distributed software components, B2B, B2C or M2M models and SOA architectures) to reach a scalable, flexible and realistic model of robots and multi-robot systems that allows us to contemplate each element that makes up a service, independently of its nature, ubicacion or any other type of physical restriction.

This paper considers which are the most suitable technologies used in other fields, particularly in business, and it also studies their application in robot modelling. The existing business-robot parallelism is analyzed as well as the logic of electronic business-components and the distributed software component concept is found to be the convergence point. Therefore, the first aspect to be approached is the process that we term normalization of components which allows us to characterize the electromechanical elements of the robotic system as software components. In this way, all the components of the robot are aligned, both physically and conceptually, for services and, finally, an n-tier based architecture is proposed to integrate them all within the same conceptual model.

2 BACKGROUND

In recent years, robotics has experienced a great advance in the many fields involved (Torres et al, 2002). Nevertheless, these advances have not affected all the tasks that a robot may carry out to the same extent. This may be explained by the fact that the models and architectures used were not the most suitable in order to obtain more far-reaching objectives (Minsky, 2000). Aspects such as cognition or commonsense arise from the interaction of individuals, with their context or with other individuals. Therefore, models and distributed architectures that can support these multitudinal ecosystems are required (Oatley, 2000). There are a great number of projects that deal with collaborative systems by which it is possible to conceive the appropriate mechanisms and functionality of independent techniques so that several robots can establish relationships with each other and efficiently obtain the fulfillment of a task (Grob et al, 2006). These studies explore the robustness, flexibility and ability to solve complex problems, by using the parallelism and self-organization of robotic communities composed of independent and even heterogenous individuals (Mondada et al, 2004). Many of these studies propose a technological framework that may serve as a standard platform in the area of robotics (Spears et al, 2004) and which allows the implementation of the system to be separated from the physical layer (Perez, 2000).

The use of alternative communication mechanisms to replace traditional systems and the study of possible relationships and their formalisation are beginning to be used for this purpose (Sekmen, 2004). For many years, fields that are closely linked to robotics, such as sensing or monitoring, have focused on the use and application of internet-related technologies for the development of intelligent or embedded networks (Tao Et al, 2004), since these technologies are low cost, highly sophisticated, far-reaching and socially acceptable. Furthermore, they are now the main tools for enabling distributed infrastructures to be established and to overcome barriers related to physical technologies (Delin et al, 2005).

The miniaturization capacity allows us to incorporate computation in practically any component (Gilart et al, 2006). The concept of pervasive computing along with communications technologies can be applied to all areas, for example, using encrusted devices to provide internet-based interfaces as a device management mechanism (Ju et al, 2000). Some of the latest studies propose

intelligent environments combining the use of embedded sensors and ontology-based contexts (Tan et al, 2005). The success of embedded computation is evident due to the transparent incorporation of ITC into daily life (Hansmann Et al the 2003).

3 NORMALIZATION OF COMPONENTS

The aim of the normalization process is to characterize the elementary components of a robotic system (including sensors, actuators and computational elements) from the point of view of its contribution to the robot's functional and conceptual model. In this way, a vision is generated that firstly allows physical elements and, later, robotic processes to evolve towards ITC services. The process involves equipping each of the robot's elementary components with the required hardware infrastructure and software so that they can be displayed as software services. The new resulting components of this process are named Smart Services and allow us to raise the abstraction level of the lowest layers, until they can be compared with the rest of the robotic system's software services.

More specifically, we will firstly act on the sensors and actuators. In general, these elements do not have the capacity to process and store the information with which to operate. The first stage involves equipping these elements with the necessary hardware so that they can do so. Figure 1 shows a block diagram with the main components.

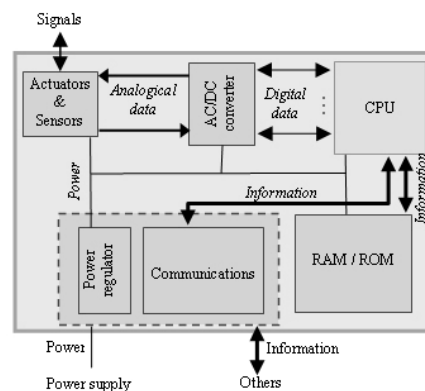

Figure 1: Physical block diagram of the Smart Service.

This hardware consists of: an analogical-digital converter that allows the analogical signals of the actuators or sensors to be adapted to those of the digital processor; a processor, equipped with computation capacity; memory to store or handle the

data obtained or processed; a communications system that adapts the information to the communication channel; and an energy regulation module that adapts input at the correct levels. The latter two modules could be integrated since existing communication protocols can unify these functions (PoE or PLC).

Once we have the necessary hardware, we can incorporate the software elements into the devices as embedded software, which will allow interaction with it as a service. In figure 2, the embedded software platform that is set out.

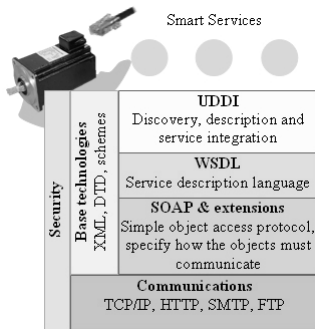

Figure 2: Logical diagram of the component.

This platform consists of: a communications layer with the standard network protocols (TCP/IP, HTTP, SMT, FTP...); a second layer where SOAP and its extensions are located; a third layer with the service description languages, WSDL; and a fourth layer where the discovery services and publication services (UDDI) will be located. The three upper layers of the platform use technology bases such as XML, DTD and schemas. The whole platform is covered by the standard network security protocols. In this way, the services offered by each component will be found in the upper levels.

These new devices, with their capacities, are what we known as Smart Sensors or Smart Actuators.

In addition to sensors and actuators, we require the rest of the computational components that make up the robotic system to be aligned technologically and functionally with these new intelligent devices. In this case, the required computational hardware platform is already available. For this reason, it will be sufficient to add the necessary architectonic software layers so that planners, gateways, trajectory calculation processes, controllers and other functionalities of the robot can also be offered as services. This type of services that originate from software processes are known as Smart Computations.

Finally, we have been able to encapsulate and hide the different physical elements involved in the system and, since they are all now shown as services, we have grouped them under the common name of Smart Services, independently of their physical nature.

Given that now there is nothing to prevent a Smart Service from being made up of other Smart Services, we can distinguish between Basic Smart Services, such as those which cannot be divided into other Smart Services, and the Compound Smart Services, which use at least one other Smart Service, which in turn may be either basic or compound.

4 CONCEPTUAL TECHNICAL ARCHITECTURE

Once all the elements have been standardized and reduced to distributed software components (Smart Services), we can apply the solutions extracted from the e-business models or, more generically, from the distributed software component-based systems.

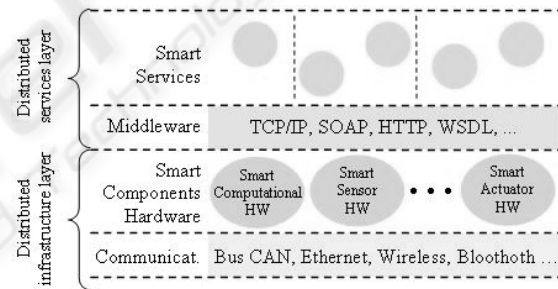

Figure 3: Conceptual technical architecture to a distributed robotic system based on Smart Services.

In the case of the technical architecture of the robot, an n-level architecture can be applied where a homogenous and structured panorama is formed in layers. A communications level is determined to support the Smart Service hardware, which is formed by the whole physical layer which makes up each of the components. The Middleware layer is comprised of the software that allows us to manage the described communications and processing mechanisms. It will be composed of the transmission protocols, messages language, component access protocols, discovery protocols, etc. This level is responsible for abstracting the traditional components towards the world of the services. As regards the technical physical architecture, each intelligent hardware component, together with its

service layer, constitutes a container upon which are executed the distributed software components that implement their business logic or, in terms of the robotic system, the functionality of their components. The service layer is the platform for developing the software components that provide the functionality and interface that the Smart Service is able to offer to other components, whether they belong to the same robot or to any other client with the sufficient capacity and permission to call it.

The resulting architecture is known as Service-Oriented Robotic Architecture and incorporates characteristics such as the organization of the elements involved into perfectly defined compartments and interfaces.

5 CONCLUSIONS

In this paper we propose a conceptualization that breaks down the architecture of the underlying technology and frees the traditional organisational schemas of their limitations; it allows us to disconnect the disciplines involved in the development of projects by elevating the functionality of the minimum components, thanks to the appearance of middleware; and it homogenizes the technologies that will be used when separating and organizing the different functional aspects in layers and levels with well-defined interfaces.

The benefits not only affect the architectonic aspects, but they also allow us to take advantage of the conceptual and organisational characteristics of the service paradigm, ensuring a simpler integration based on standards, scalability, regardless of the platform and manufacturer, and using realistic development tools. The technological gap that separates implementation models is reduced as since the minimum elements of the robotic systems are technologically more advanced.

Finally, the proposed approach opens the door to acquiring new capabilities such as self-repair, self-assembly or service replication, since the technologies that sustain the service paradigm can support or implement mechanisms related to these proposals.

REFERENCES

- Delin, K., Jackson, S., Johnson, D., Burleigh, S., Woodrow, R., McAuley, M., Dohm, J., Ip, F., Ferré, T., Rucker, D., Baker, V. "Environmental Studies with the Sensor Web: Principles and Practice". Sensors. Vol. 5, 2005. pp 103-117.
- Gilart, V., Ramos, H., Maciá, P. "Del eBusiness al Smartscrew" en Maciá, F. y García, J. M. (ed.), Servicios Electrónicos para la Sociedad de la Información. San Vicente del Raspeig. Publicaciones de la Universidad de Alicante. 2006
- Grob, R., M. Bonani, M., Mondada, F., Dorigo, M. "Autonomous Self-assembly in a Swarm-Bot". Proceedings of the Third International Symposium on Autonomous Minirobots for Research and Edutainment. Springer. Verlag.
- Hansmann, U., Merk, L., Nicklous, M., Stober, T. "Pervasive Computing". Böblingen, Germany. Springer. 2003.
- Ju, H. T, Choi, M. J., Hong, J. "An efficient and lightweight embedded Web server for Web-based network element management". International Journal of Network Management. Vol. 10, num. 5, 2000.. ISSN:1099-1190. pp. 261-275.
- Minsky, M. L.. "DRAFT. Future Models for Mind-Machines". Proceedings of the AISB'00 Symposium on Creative & Cultural Aspects and Applications of AI & Cognitive Science. Birmingham. pp.41-53. 2000.
- Mondada, F., Pettinaro, G., Guignard, A., Kwee, I., Floreano, D., Deneubourg, J., Nolfi, S., Gambardella, L., Dorigo, M. "Swarm-Bot: a New Distributed Robotic Concept". Autonomous Robots. Vol 17, 2004. ISSN: 0929-5593. pp. 193-221.
- Oatley, K. "Shakespeare's invention of theatre as simulation that runs on minds". Proceedings of the AISB'00 Symposium on Creative & Cultural Aspects and Applications of AI & Cognitive Science. pp.41-53. Birmingham, UK, 2000. ISBN 1 902956
- Pérez, A., 2000. "Of implementing neural epigenesis, reinforcement learning, and mental rehearsal in a mobile autonomous robot". Proceedings of the AISB'00 Symposium on Creative & Cultural Aspects and Applications of AI & Cognitive Science. Birmingham, ISBN 1 902956, pp.41-53.
- Sekmen, A. "Multi-Robot Communication via Grid Services". IASTED International Conference on Robotics and Applications. Honolulu. 2004
- Spears, W., Gordon-Spears, D., Heil, R. "Distributed, Physics-Based Control of Swarm of Vehicles". Autonomous Robots. Vol. 17, 2004. ISSN: 0929-5593. pp. 137-162.
- Tan, J. G., Zhang, D., Wang, X., Cheng, H. "Enhancing semantic spaces with event-driven context interpretation". En Gellersen, H. W., Want, R. y Schmidt, A., Pervasive Computing. 2005. LNCS 3468. ISSN: 0302-9743, pp. 80-97.
- Tao, V., Liang, S., Croitoru, A. "GeoSWIFT: Open Geospatial Sensing Services for Sensor Web". in A. Stefanidis and S. Nittel (ed.), GeoSensor Networks. CRC Press. 2004. ISBN: 0415324041, pp. 80-86.
- Torres, F., Pomares, J., Gil, S., Aracil, R. "Robots y Sistemas Sensoriales". Prentice-Hall. 2000.