

ON JUST IN TIME CONTROL OF SWITCHING MAX-PLUS LINEAR SYSTEMS

Michel Alsaba, Sébastien Lahaye and Jean-Louis Boimond

LISA

62 avenue Notre Dame du Lac - Angers, France

Keywords: Discrete event systems, $(\max, +)$ algebra, switching max-plus linear systems, just in time control.

Abstract: Discrete event systems involving synchronization and delay phenomena can be described by a linear state representation over $(\max, +)$ algebra. Some discrete event systems involving choice phenomena could be transformed, under some conditions, into switching max-plus linear systems modeled as automata. The switching between states of these automata is governed by a switching variable. This paper deals with the just in time control of these switching max-plus linear systems. The control problem we propose is optimal under just in time criterion when the switching variable is given on the study horizon.

1 INTRODUCTION

The class of Discrete Event Systems (DES) essentially consists of man-made systems that contain a finite number of resources (such as machines, communications channels, or processors) shared by several users (such as product types, information packets, or jobs) all of which contributing to the achievement of some common goal as the assembly of products, the end to end transmission of a set of information packets, or a parallel computation, (Baccelli et al., 1992). In general, models of DES are nonlinear in conventional algebra. However, there exists a class of DES which have been shown to be linear in a particular algebraic structure, namely *max-plus algebra* (Baccelli et al., 1992). The so-called *max-plus linear systems* involve only synchronization and delay phenomena (but no conflict) which are basically modeled by maximization and addition operations. Regarding Timed Petri Nets (TPN) which enable to model (and partly analyze) a wide variety of DES, max-plus linear systems mainly fit to the subclass of Timed Event Graphs (TEG).

Several studies have attempted to widen the class of DES likely to be analyzed thanks to max-plus algebraic tools. Among those works, we focus in this paper on the so-called *switching max-plus linear systems* which have been introduced in (van den Boom and de Schutter, 2004). They can be seen as an automaton switching between several max-plus linear

state representations. They are an adequate tool to model DES in which several modes of operation take effect. Beside max-plus linear models, switching allow to take into account additional phenomena such as breaks of synchronization and changes in events occurrences order. In (van den Boom and de Schutter, 2004), authors have proposed a model predictive control for such systems to optimize their behavior. In this paper, we tackle another control problem, namely the output tracking problem with respect to just in time criterion. This control have been extensively studied for max-plus linear systems notably in (Cohen et al., 1989), (Menguy et al., 2000). Under particular assumptions, we show that switching max-plus linear systems admit representations and a just-in-time control solution inspired by those of max-plus linear time-varying systems (Lahaye et al., 1999). The contribution lies in the possibility to take into account changes in the system structure while only parameters may vary in the time-varying case.

This paper is organized as follows. Some results used in the sequel are recalled in the second section. A general presentation about switching max-plus linear systems is given in the third section. We expose the JIT control problem of such systems in the fourth section. We give two applications in the fifth section.

2 PRELIMINARIES

2.1 Algebraic Tools

2.1.1 Dioid

See (Cohen et al., 1989), (Baccelli et al., 1992, §4) for an exhaustive presentation of dioid theory.

A dioid $(\mathcal{D}, \oplus, \otimes)$ is an idempotent¹ semiring, neutral elements of \oplus and \otimes are denoted ε and e respectively. The symbol \otimes is often omitted.

A dioid \mathcal{D} is *complete* if it is closed for infinite sums and if the product distributes over finite and infinite sums. The upper bound of a complete dioid, denoted \top (for Top), is the sum of all dioid elements and it is absorbing for the addition.

An *order relation*, noted \succeq , can be associated with a dioid \mathcal{D} by the following equivalence: $\forall a, b \in \mathcal{D}, a \succeq b \Leftrightarrow a = a \oplus b$. This order relation confers upon complete dioid a structure of complete lattice. So, we can introduce an operator *Inf*, denoted \wedge , verifying: $\forall a, b \in \mathcal{D}, a \succeq b \Leftrightarrow b = a \wedge b$.

Example 1 The set $\mathbb{Z} \cup \{-\infty, +\infty\}$, endowed with the max operator as additive law and the classical sum as product, is a complete dioid, usually denoted by $\overline{\mathbb{Z}}_{\max}$, with $\varepsilon = -\infty, e = 0$ and $\top = +\infty$.

If \mathcal{D} is a dioid, the set $\mathcal{D}^{n \times n}$ of $n \times n$ matrices with coefficients in \mathcal{D} is also a dioid. Sum and product are defined in the following way:

$$(A \oplus B)_{ij} = A_{ij} \oplus B_{ij}, (A \otimes B)_{ij} = \bigoplus_{k=1}^n A_{ik} \otimes B_{kj}.$$

Theorem 1 Over a complete dioid \mathcal{D} , the implicit equation $x = ax \oplus b$ admits a^*b as least solution where $a^* = \bigoplus_{i \in \mathbb{N}} a^i$ with $a^0 = e$.

2.1.2 Residuation Theory

A complete presentation of this theory is given in (Blyth and Janowitz, 1972), see (Baccelli et al., 1992, §4.4) for a specialization to dioid.

Residuation theory provides, under some assumptions, the *greatest* solution to inequality $f(x) \preceq b$, where f is an isotone mapping² defined over ordered sets.

An isotone mapping $f : \mathcal{D} \rightarrow \mathcal{F}$, where $(\mathcal{D}, \preceq_{\mathcal{D}})$ and $(\mathcal{F}, \preceq_{\mathcal{F}})$ are ordered sets, is a *residuated mapping* if for all $b \in \mathcal{F}$ the upper bound of the subset $\{x \in \mathcal{D} \mid f(x) \preceq_{\mathcal{F}} b\}$ exists and belongs to this subset.

Theorem 2 Let $f : \mathcal{D} \rightarrow \mathcal{F}$ be an isotone mapping from the complete dioid $(\mathcal{D}, \preceq_{\mathcal{D}})$ into the complete dioid $(\mathcal{F}, \preceq_{\mathcal{F}})$. The following statements are equivalent:

¹ $\forall a \in \mathcal{D}, a \oplus a = a$.

² f is an isotone mapping if $a \preceq b \Rightarrow f(a) \preceq f(b)$.

(i) f is residuated.

(ii) There exists a unique isotone mapping $f^{\#} : \mathcal{F} \rightarrow \mathcal{D}$, called *residual*, such that $f \circ f^{\#} \preceq_{\mathcal{F}} id_{\mathcal{F}}$ and $f^{\#} \circ f \succeq_{\mathcal{D}} id_{\mathcal{D}}$ where $id_{\mathcal{F}}$ and $id_{\mathcal{D}}$ are identity mappings in \mathcal{F} and \mathcal{D} respectively.

Example 2 Mappings $L_a : x \mapsto a \otimes x$ and $R_a : x \mapsto x \otimes a$ defined over a complete dioid \mathcal{D} are both residuated. Their residuals are usually denoted by $L_a^{\#}(x) = a \backslash x$ and $R_a^{\#}(x) = x / a$ respectively. These 'quotients' satisfy the following formulae:

$$a \otimes (a \backslash x) \preceq x, (x / a) \otimes a \preceq x, \quad (i)$$

$$a \backslash (x \wedge y) = (a \backslash x) \wedge (a \backslash y), \quad (ii)$$

$$(x \wedge y) / a = (x / a) \wedge (y / a), \quad (iii)$$

$$(a \otimes b) \backslash x = b \backslash (a \backslash x), x / (a \otimes b) = (x / a) / b. \quad (iv)$$

3 LINEAR SYSTEMS

3.1 Max-plus Linear Systems

It has been shown that DES involving synchronization and delay phenomena (but no choice phenomenon) can be described by a linear state representation over dioid $\overline{\mathbb{Z}}_{\max}$ (see (Baccelli et al., 1992) for a detailed presentation):

$$\begin{cases} x(k) &= A(k)x(k-1) \oplus B(k)u(k), \\ y(k) &= C(k)x(k). \end{cases} \quad (1)$$

Such systems are usually referred to as (max, +) *linear systems*. The index k is called the event counter. Entries of state vector $x(k)$ are *daters functions* expressing the time instants at which the internal events occur for the k -th time. Similarly, vectors $u(k)$ and $y(k)$ contain *daters* associated respectively with input and output events.

3.2 Switching Max-plus Linear Systems

We now consider so-called *switching max-plus linear systems* introduced and studied in (van den Boom and de Schutter, 2004). This class of systems corresponds to DES that can switch between different modes of operation. In each mode $l = 1, \dots, q$, the system is described by a (max, +) linear state space model:

$$\begin{cases} x(k) &= A^{(l)}(k)x(k-1) \oplus B^{(l)}(k)u(k), \\ y(k) &= C^{(l)}(k)x(k). \end{cases} \quad (2)$$

in which the matrices $A^{(l)}, B^{(l)}$ and $C^{(l)}$ are the system matrices for the l -th mode. In general the switching allows to model a change in the structure of the system, such as breaking a synchronization or changing the events occurrences order (several examples are proposed in (van den Boom and de Schutter, 2004)).

The moments of switching are determined by a switching mechanism. A switching variable $\sigma(k)$ is defined, which may depend on the previous state $x(k-1)$, the previous mode $l(k-1)$, the input variable $u(k)$ and/or an external decision variable $v(k)$:

$$\sigma(k) = \Phi(x(k-1), l(k-1), u(k), v(k)) \in \mathbb{R}^{n_\sigma}. \quad (3)$$

Set \mathbb{R}^{n_σ} is partitioned in q subsets $\mathbf{Z}^{(i)}, i = 1 \dots q$. The mode $l(k)$ is now obtained by determining in which subset $\sigma(k)$ is for event k . So if $\sigma(k) \in \mathbf{Z}^{(i)}$, then $l(k) = i$. We represent on figure 1 a simple switching max-plus linear system with two modes.

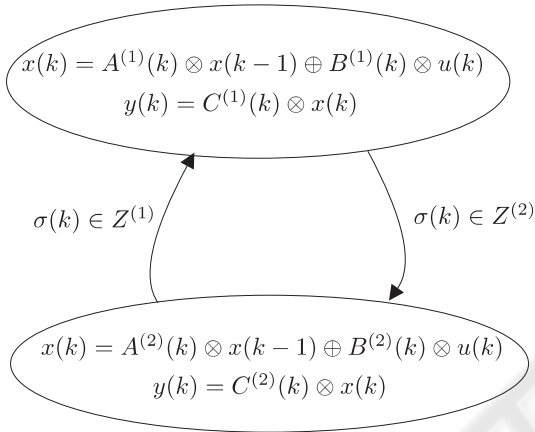

Figure 1: A simple switching max-plus linear system.

4 REPRESENTATIONS AND JUST IN TIME CONTROL OF SWITCHING MAX-PLUS LINEAR SYSTEMS

In this section, we first focus on representations of switching max-plus linear systems. Assuming that the switching variable is known on the study horizon, we explicit the solution of state equation (2) and identify its impulse response. The obtained representations are reminiscent of those of $(\max, +)$ linear time-varying systems (Lahaye et al., 1999), except that structures of implied matrices may vary along evolution in the switching case, while only parameters may vary in the time-varying case.

From these representations, we can next tackle a control problem for switching max-plus linear systems, namely *the output tracking problem with respect to just in time criterion*.

4.1 Representations

In the following, we assume that switching variable $\sigma(k)$ is known on the study horizon. Referring to equation (3), this may happen in particular if:

1. $\sigma(k) = \Phi(v(k))$, in which the external decision variable $v(k)$ is supposed to be given on the study horizon.
2. $\sigma(k) = \Phi(l(k-1))$, where function $l(k)$, stating the mode at step k according to the previous one, is supposed to be given on the study horizon.

So the first equation of (2) can be written for $k \geq k_0$:

$$x(k) = \Phi(k, k_0)x(k_0) \oplus \bigoplus_{j=k_0+1}^k \Phi(k, j)B^{(l)}(j)u(j)$$

where $\Phi(k, i)$ is the *transition matrix* given by:

$$\Phi(k, i) = \begin{cases} \text{not defined} & \text{if } i > k, \\ Id & \text{if } i = k, \\ A^{(l)}(k)A^{(l)}(k-1)\dots A^{(l)}(i+1) & \text{otherwise.} \end{cases}$$

Then, we deduce the output:

$$y(k) = C^{(l)}(k)\Phi(k, k_0)x(k_0) \oplus \bigoplus_{j=k_0+1}^k C^{(l)}(k)\Phi(k, j)B^{(l)}(j)u(j) \quad (4)$$

Remark 1 *The state-transition matrix satisfies the composition property*

$$\Phi(k, i) = \Phi(k, j) \otimes \Phi(j, i), \text{ where } k \geq j \geq i,$$

and in particular for $k \geq i + 1$

$$\Phi(k, i) = A^{(l)}(k)\Phi(k-1, i) = \Phi(k, i+1)A^{(l)}(i+1).$$

Proposition 1 *The least solution of equations (2) is given by $\forall k \in \mathbb{Z}, \bar{y}(k) = \bigoplus_{j \leq k} h(k, j)u(j)$ with*

$$h(k, j) = C^{(l)}(k)\Phi(k, j)B^{(l)}(j), \text{ for } j \leq k.$$

h is called the impulse response of the system.

Proof *By tending k_0 towards $-\infty$ in equation (4), it is clear that any solution is greater than \bar{y} .*

Setting $\bar{y}(k) = C^{(l)}(k)\bar{x}(k)$ with

$$\bar{x}(k) = \bigoplus_{j \leq k} \Phi(k, j)B^{(l)}(j)u(j),$$

We show that \bar{x} satisfies the first equation of (2):

$$\begin{aligned} \bar{x}(k) &= \bigoplus_{j \leq k} \Phi(k, j)B^{(l)}(j)u(j), \\ &= \bigoplus_{j \leq k-1} \Phi(k, j)B^{(l)}(j)u(j) \oplus B^{(l)}(k)u(k), \\ &= A^{(l)}(k) \left[\bigoplus_{j \leq k-1} \Phi(k-1, j)B^{(l)}(j)u(j) \right] \\ &\quad \oplus B^{(l)}(k)u(k), \text{ (thanks to remark 1)} \\ &= A^{(l)}(k)\bar{x}(k-1) \oplus B^{(l)}(k)u(k). \quad \square \end{aligned}$$

4.2 Just In Time Control of Switching Max-plus Linear Systems

4.2.1 Description

Strong analogies appear between the classical linear system theory and the (max, +) linear system theory. In particular, the concept of *control* is now well defined for these systems. A *greatest control*, based on residuation theory (Blyth and Janowitz, 1972), has been proposed in (Cohen et al., 1989), (Menguy et al., 2000). For a given reference input (*i.e.*, desired dates of occurrence for output events) $Z = \{z(k)\}_{k=0, \dots, k_f}$, the control yields the *latest* dates of occurrence for input events $U = \{u(k)\}_{k=0, \dots, k_f}$ in order that the output events $Y = \{y(k)\}_{k=0, \dots, k_f}$ occur before the reference input. Such a greatest control is called Just In Time (JIT) control. In a production context, it amounts to satisfying the customer demand while minimizing the stocks. Using representations proposed at section 4.1, we propose a JIT control for switching Max-plus linear systems.

4.2.2 Control Problem for Switching Max-plus Linear Systems

Proposition 2 *From proposition 1, the output y of a switching max-plus linear system can be written as $y = \mathcal{H}(u)$ where $[\mathcal{H}(u)](k) = \bigoplus_{j \leq k} h(k, j)u(j)$.*

Then the JIT optimal control, denoted $u_{opt}(k)$, is given by:

$$u_{opt}(k) = [\mathcal{H}^\sharp(z)](k) = \bigwedge_{j \geq k} h(j, k) \backslash z(j).$$

Proof We denote ω the signal defined by:

$$\forall k \in \mathbb{Z}, \omega(k) = \bigwedge_{j \geq k} h(j, k) \backslash z(j).$$

1. Let x satisfying $\mathcal{H}(x) \preceq Z$ or equivalently,

$$\forall k \in \mathbb{Z}, \bigoplus_{i \in \mathbb{Z}} h(k, i)x(i) = \bigoplus_{i \leq k} h(k, i)x(i) \preceq z(k)$$

$$\forall k, i \in \mathbb{Z}, i \leq k; h(k, i)x(i) \preceq z(k)$$

$$\forall k, i \in \mathbb{Z}, i \leq k; x(i) \preceq h(k, i) \backslash z(k)$$

$$\forall i \in \mathbb{Z}, x(i) \preceq \bigwedge_{k \geq i} h(k, i) \backslash z(k) = \omega(i)$$

2. Using (i), $\forall k \in \mathbb{Z}$,

$$\bigoplus_{i \in \mathbb{Z}} h(k, i)\omega(i) = \bigoplus_{i \in \mathbb{Z}} h(k, i) \left[\bigwedge_{j \geq i} h(j, i) \backslash z(j) \right] \preceq$$

$$\bigoplus_{i \in \mathbb{Z}} h(k, i) \left[h(k, i) \backslash z(k) \right] \preceq \bigoplus_{i \in \mathbb{Z}} z(k) = z(k) \text{ which}$$

shows that ω is solution of $\mathcal{H}(x) \preceq Z$. \square

In the following, we show that u_{opt} is solution of a system of recurrent equations which proceed backwards in event index. These equations offer a

strong analogy with the adjoint-state equations of optimal control theory. Firstly let us remark using (iv) that:

$$\begin{aligned} u_{opt}(k) &= \bigwedge_{j \geq k} h(j, k) \backslash z(j) \\ &= \bigwedge_{j \geq k} (C^{(l)}(j)\Phi(j, k)B^{(l)}(k)) \backslash z(j) \\ &= \bigwedge_{j \geq k} B^{(l)}(k) \backslash [(C^{(l)}(j)\Phi(j, k)) \backslash z(j)] \\ &= B^{(l)}(k) \backslash \bar{\xi} \end{aligned}$$

when setting

$$\bar{\xi}(k) = \bigwedge_{j \geq k} (C^{(l)}(j)\Phi(j, k)) \backslash z(j).$$

Proposition 3 *The greatest solution of equation:*

$$\xi(k) = A^{(l)}(k+1) \backslash \xi(k+1) \wedge C^{(l)}(k) \backslash z(k) \quad (5)$$

is given by:

$$\bar{\xi}(k) = \bigwedge_{j \geq k} (C^{(l)}(j)\Phi(j, k)) \backslash z(j).$$

Proof

1. Let us first show that $\bar{\xi}$ is solution of equation (5).

$$\forall k \in \mathbb{Z},$$

$$A^{(l)}(k+1) \backslash \bar{\xi}(k+1) \wedge C^{(l)}(k) \backslash z(k)$$

$$= A^{(l)}(k+1) \backslash \left[\bigwedge_{i \geq k+1} (C^{(l)}(i)\Phi(i, k+1)) \backslash z(i) \right] \wedge$$

$$C^{(l)}(k) \backslash z(k)$$

$$= \bigwedge_{i \geq k+1} (C^{(l)}(i)\Phi(i, k+1)A^{(l)}(k+1)) \backslash z(i) \wedge$$

$$C^{(l)}(k) \backslash z(k) \quad (\text{thanks to (ii) and (iv)})$$

$$= \bigwedge_{i \geq k+1} (C^{(l)}(i)\Phi(i, k)) \backslash z(i) \quad \wedge$$

$$(C^{(l)}(k)\Phi(k, k)) \backslash z(k) \quad (\text{see remark 1})$$

$$= \bigwedge_{i \geq k} (C^{(l)}(i)\Phi(i, k)) \backslash z(i) \quad (\text{thanks to (ii)})$$

$$= \bar{\xi}(k)$$

2. Let $\{\xi(k)\}_{k \in \mathbb{Z}}$ a solution of equation (5), we have

$$\forall k \in \mathbb{Z}$$

$$\xi(k) = \Phi(k + k_0, k) \backslash \xi(k + k_0) \wedge$$

$$\bigwedge_{j=k}^{k+k_0-1} (C^{(l)}(j)\Phi(j, k)) \backslash z(j), k_0 \geq 1.$$

With $k_0 \rightarrow +\infty$, it is clear that $\forall k, \xi(k) \preceq \bar{\xi}(k)$. \square

So finally, $\{u_{opt}(k)\}_{k \in \mathbb{Z}}$ can be computed using the following backward iterative procedure:

$$\begin{cases} \xi(k) &= A^{(l)}(k+1) \backslash \xi(k+1) \wedge C^{(l)}(k) \backslash z(k), \\ u_{opt}(k) &= B^{(l)}(k) \backslash \xi(k). \end{cases}$$

5 APPLICATION

5.1 Example 1

This is a generic example because in much industrial applications (specially in flexible manufacturing sys-

tems) we find shared resources (as a welding or painting robot shared between production lines). Output parts of this stage are processed by the machine $M3$. Using Petri nets to model shared resources leads to a structure of choice represented by a place P (see figure 2) with an input fork of arcs and another one outgoing. The three machines used $M1, M2, M3$ have one server each, which means that each one treats one product at once. Processing times on machines M_1, M_2 and M_3 are respectively 3, 1 and 3 units of time.

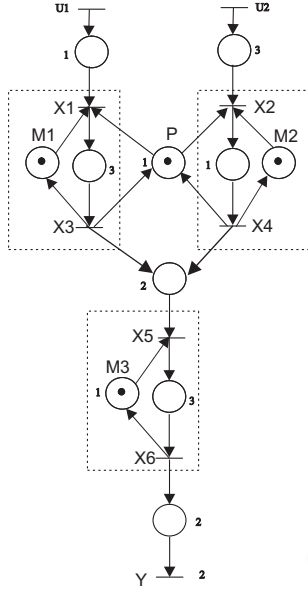

Figure 2: Petri net model for example 1.

$$\text{If } l(k) = 1 \text{ then } u(k) = U_1(k),$$

$$x(k) = \begin{pmatrix} x_1(k) \\ x_2(k) \\ x_3(k) \\ x_4(k) \end{pmatrix} = \begin{pmatrix} X1(k) \\ X3(k) \\ X5(k) \\ X6(k) \end{pmatrix} \text{ else}$$

$$u(k) = U_2(k), \quad x(k) = \begin{pmatrix} x_1(k) \\ x_2(k) \\ x_3(k) \\ x_4(k) \end{pmatrix} = \begin{pmatrix} X2(k) \\ X4(k) \\ X5(k) \\ X6(k) \end{pmatrix}.$$

Considering the first case which means $l(k) = 1$ we will give how we can extract the state space

$$\text{equations:}$$

$$\begin{aligned} x_1(k) &= 1x_2(k-1) \oplus 1u(k), \\ x_2(k) &= 3x_1(k), \\ x_3(k) &= 2x_2(k) \oplus 1x_4(k-1), \\ x_4(k) &= 3x_3(k), \\ Y(k) &= x_4(k), \end{aligned}$$

$$\alpha_{(1)}(k) = \begin{pmatrix} \varepsilon & \varepsilon & \varepsilon & \varepsilon \\ 3 & \varepsilon & \varepsilon & \varepsilon \\ \varepsilon & 2 & \varepsilon & \varepsilon \\ \varepsilon & \varepsilon & 3 & \varepsilon \end{pmatrix},$$

$$\alpha_{(2)}(k) = \begin{pmatrix} \varepsilon & 1 & \varepsilon & \varepsilon \\ \varepsilon & \varepsilon & \varepsilon & \varepsilon \\ \varepsilon & \varepsilon & \varepsilon & 1 \\ \varepsilon & \varepsilon & \varepsilon & \varepsilon \end{pmatrix},$$

Table 1: Numerical data and optimal control for system represented on figure 2.

k	0	1	2	3	4	5	6	7
$z(k)$	21	22	24	25	29	33	35	39
$l(k)$	2	1	1	1	2	1	2	2
$u_{opt_1}(k)$		4	8	12		20		
$u_{opt_2}(k)$	0				16		24	28
$y(k)$	11	15	19	23	27	31	35	39

$$\alpha_{(3)}(k) = \begin{pmatrix} \varepsilon & \varepsilon & \varepsilon & \varepsilon \\ 1 & \varepsilon & \varepsilon & \varepsilon \\ \varepsilon & 2 & \varepsilon & \varepsilon \\ \varepsilon & \varepsilon & 3 & \varepsilon \end{pmatrix},$$

$$\beta_{(1)}(k) = \begin{pmatrix} 1 \\ \varepsilon \\ \varepsilon \\ \varepsilon \end{pmatrix}, \quad \beta_{(2)}(k) = \begin{pmatrix} 3 \\ \varepsilon \\ \varepsilon \\ \varepsilon \end{pmatrix}.$$

Now using theorem 1, we get:

$$A^{(1)}(k) = (\alpha_{(1)}^*) \otimes \alpha_{(2)} = \begin{pmatrix} \varepsilon & 1 & \varepsilon & \varepsilon \\ \varepsilon & 4 & \varepsilon & \varepsilon \\ \varepsilon & 6 & \varepsilon & 1 \\ \varepsilon & 9 & \varepsilon & 4 \end{pmatrix},$$

$$A^{(2)}(k) = (\alpha_{(3)}^*) \otimes \alpha_{(2)} = \begin{pmatrix} \varepsilon & 1 & \varepsilon & \varepsilon \\ \varepsilon & 2 & \varepsilon & \varepsilon \\ \varepsilon & 4 & \varepsilon & 1 \\ \varepsilon & 7 & \varepsilon & 4 \end{pmatrix},$$

$$B^{(1)}(k) = (\alpha_{(1)}^*) \otimes \beta_{(1)} = \begin{pmatrix} 1 \\ 4 \\ 6 \\ 9 \end{pmatrix},$$

$$\text{in the same way we get: } B^{(2)}(k) = \begin{pmatrix} 3 \\ 4 \\ 6 \\ 9 \end{pmatrix}.$$

Considering that the switching variable $\sigma(k)$ is known on the horizon of study, and consequently $l(k)$ will be known too, so we can apply the proposed method for a just in time control. Table 1 shows a numerical experimentation: $z(k)$ corresponds to the desired delivery date for the k -th finished piece, $l(k)$ gives the machine number which treats the k -th part, $u_{opt_1}(\cdot)$ and $u_{opt_2}(\cdot)$ are the computed optimal inputs, and $y(\cdot)$ is the output response to $u_{opt_1}(\cdot)$ and $u_{opt_2}(\cdot)$. We verify that for all k we have $y(k) \preceq z(k)$.

5.2 Example 2

We consider a manufacturing system consisting of three machines. It is supposed to produce one kind of piece by assembling two kinds of raw parts denoted P_1 and P_2 . Two modes can be chosen along production. In a first mode, parts P_1 (resp. P_2) are preprocessed on machine M_1 (resp. M_2) and finally assembled and processed on machine M_3 . In the second mode, parts P_1 and P_2 are assembled and preprocessed on machine M_1 , and then processed successively by machines M_2 and M_3 . Routings

of parts are depicted on figure 3. When a switch between modes occurs, we assume that semi-finite pieces preprocessed by machines 1 and 2 (stocked in their downstream buffers) can be processed indifferently by downstream machines in the new mode. Furthermore, we assume that there are no set-up-times on machines when they switch from one mode to another. Processing times on machines M_1 , M_2 and M_3 are respectively 3, 4 and 5 units of time.

Functioning of the system can be represented by a max-plus linear state equation (2) specific to each mode. In both modes, we associate two input *daters* denoting dates at which raw parts P_1 and P_2 are released in production. Six state *daters* are used to respectively represent input and output dates of parts on machines M_1 , M_2 and M_3 . Finally, one output *dater* denotes delivering dates of finished parts. We get the following representations:

$$A^{(1)}(k) = \begin{pmatrix} \varepsilon & 0 & \varepsilon & \varepsilon & \varepsilon & \varepsilon \\ \varepsilon & 3 & \varepsilon & \varepsilon & \varepsilon & \varepsilon \\ \varepsilon & \varepsilon & \varepsilon & 0 & \varepsilon & \varepsilon \\ \varepsilon & \varepsilon & \varepsilon & 4 & \varepsilon & \varepsilon \\ \varepsilon & 3 & \varepsilon & 4 & \varepsilon & 0 \\ \varepsilon & 8 & \varepsilon & 9 & \varepsilon & 5 \end{pmatrix},$$

$$B^{(1)}(k) = \begin{pmatrix} 0 & \varepsilon \\ 3 & \varepsilon \\ \varepsilon & 0 \\ \varepsilon & 4 \\ 3 & 4 \\ 8 & 9 \end{pmatrix},$$

$$A^{(2)}(k) = \begin{pmatrix} \varepsilon & 0 & \varepsilon & \varepsilon & \varepsilon & \varepsilon \\ \varepsilon & 3 & \varepsilon & \varepsilon & \varepsilon & \varepsilon \\ \varepsilon & 3 & \varepsilon & 0 & \varepsilon & \varepsilon \\ \varepsilon & 7 & \varepsilon & 4 & \varepsilon & \varepsilon \\ \varepsilon & 7 & \varepsilon & 4 & \varepsilon & 0 \\ \varepsilon & 12 & \varepsilon & 9 & \varepsilon & 5 \end{pmatrix},$$

$$B^{(2)}(k) = \begin{pmatrix} 0 & 0 \\ 3 & 3 \\ 3 & 3 \\ 7 & 7 \\ 7 & 7 \\ 12 & 12 \end{pmatrix},$$

$$C^{(1)}(k) = C^{(2)}(k) = (\varepsilon \quad \varepsilon \quad \varepsilon \quad \varepsilon \quad \varepsilon \quad 0).$$

Considering that the switching variable $\sigma(k)$ is known on the horizon of study, and consequently $l(k)$ will be known too, so we can apply the proposed method for a just in time control. Table 2 shows a numerical experimentation: $z(k)$ corresponds to the desired delivery date for the k -th finished piece, $l(k)$ gives the mode of production chosen for the k -th part, $u_{opt_1}(\cdot)$ and $u_{opt_2}(\cdot)$ are the computed optimal inputs, and $y(\cdot)$ is the output response to $u_{opt_1}(\cdot)$ and $u_{opt_2}(\cdot)$. We verify that $\forall k$ we have $y(k) \preceq z(k)$.

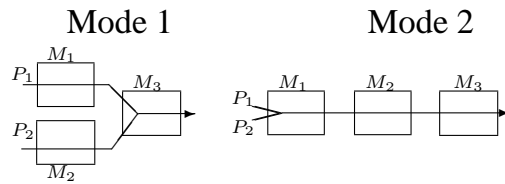

Figure 3: Routings of parts along machines according to modes of production.

Table 2: Numerical data and optimal control for example 2.

k	0	1	2	3	4	5	6	7	8
$z(k)$	15	20	35	45	60	75	80	95	100
$l(k)$	1	1	2	2	2	1	2	1	2
$u_{opt_1}(k)$	7	12	27	37	52	67	72	85	88
$u_{opt_2}(k)$	6	11	26	36	51	66	71	86	88
$y(k)$	15	20	35	45	60	75	80	95	100

6 CONCLUSION

In this paper we have considered the just in time control problem of switching max-plus linear systems. The proposed control is optimal under just in time criterion in the case where the switching variable is given on the study horizon. In futur work, we will consider a different switching variable more general which is not necessarily given from the beginning.

REFERENCES

- Baccelli, F., Cohen, G., Olsder, G.-J., and Quadrat, J.-P. (1992). *Synchronization and Linearity: An Algebra for Discrete Event Systems*. Wiley and Sons.
- Blyth, T. and Janowitz, M. (1972). *Residuation Theory*. Pergamon press.
- Cohen, G., Moller, P., Quadrat, J.-P., and Viot, M. (1989). Algebraic Tools for the Performance Evaluation of Discrete Event Systems. *IEEE Proceedings: Special issue on Discrete Event Systems*, 77(1):39–58.
- Lahaye, S., Boimond, J.-L., and Hardouin, L. (1999). Optimal Control of (Min,+) Linear Time-Varying Systems, Petri Nets and Performance Models. *Proceedings of PNPM'99*, pages 170–178, Zaragoza, Spain.
- Menguy, E., Boimond, J.-L., Hardouin, L., and Ferrier, J.-L. (2000). Just-In-Time Control of Timed Event Graphic Update of Reference Input, Presence of Uncontrollable Input. *IEEE Trans. on Automatic Control*, 45(11):2155–2158.
- van den Boom, T. and de Schutter, B. (2004). Modelling and Control of Discrete Event Systems Using Switching Max-Plus-Linear Systems. In *Proceedings of WODES'04*, pages 115–120, Reims, France.