

FUZZY ADAPTIVE CONTROLLER FOR A SYNCHRONOUS MACHINE

Gregorio Drayer and Miguel Strefezza

Departamento de Procesos y Sistemas, Universidad Simón Bolívar, Caracas 1081A, Venezuela

Keywords: Fuzzy control, Adaptive rules, Variable Structure Control, Synchronous machine.

Abstract: This paper presents the comparison of applying an adaptive fuzzy controller with and without a variable structure controller (VSC) for a synchronous machine. A simplified linear model of the synchronous machine connected to an infinite bus with constant impedance is used. The multivariable system was previously decoupled to make easier the application of the control schemes. To control the system, an adaptive Fuzzy PD controller is proposed and it acts both on the load variable and on the voltage variable. Then, a Fuzzy Adaptive System is designed to act over the Fuzzy controller. After this, the VSC theory is applied to the Adaptive Controller to compare both strategies. Simulation results using these two control schemes are presented. With these proposed actions, the results show a better transitory response of the system when compared with the system response using classical control.

1 INTRODUCTION

The need of energy increases every year, specially in industrially developed countries. Very complex systems have been designed and operated to supply the energy demand. These systems are networks of generators and loads connected by transmission lines that present many engineering problems with a variety of challenges. Synchronous machines are designed to feed the loads at constant frequency and voltage. Any unbalance between generation and load initiates a transient that can cause instabilities because of the net accelerating torques exerted on the rotors. Classical PID controllers can not deal effectively with many of the problems. Thus, a possible solution could be the application of nonlinear controllers (Vidyasagar,1993). Under perfect knowledge of the process and its disturbances, the nonlinear approach can provide good performances in a wide range of values.

The control of the synchronous machine can be designed by using the knowledge of the operators. Fuzzy controller design is based on converting linguistics control strategies obtained from an expert's knowledge or from the input-output data of a process (Takagi and Sugeno, 1985). Then, the control algorithm can be described by fuzzy rules of the form If-Then. One of the relevant advantages of

fuzzy controller is the absence of necessity for an analytical description of the process to be designed or implanted. Also, it can be implemented more easily. Its applications to different processes have been presented (Jang, Sun and Mizutani,1997) (Yager and Filev, 1994), but very few applications to synchronous machine systems can be found where this methodology is used.

PID controllers are frequently used in the industry. They have many advantages, but they are difficult to be tuned when a process has to be working in different set points or in a wide range. A multivariable model of the synchronous machine is used in this work. After the variables are decoupled, the main goal is to present the application of a Fuzzy Controller with fuzzy adaptive rules. Then, a fuzzy sliding controller is added to the overall adaptive fuzzy control for the load variable of a synchronous machine. The purpose is to compare the advantages of both controllers (Huang and Lin, 2003) (Li and Gatland, 1997).

Simulations are carried out, showing that the proposed strategies present good results. The description of the system is presented in section 2. The control strategy is outlined in section 3, the results of simulations based on the outlined model are showed in section 4. Finally, in section 5 the conclusions are given and recommendations are proposed.

2 MODEL OF THE SYSTEM

In this section the mathematical model describing the dynamic behavior of the synchronous machine is presented (Anderson, 1993) where state-space formulation of the machine equations is used.

In this study a simplified linear model of a synchronous machine connected to an infinite bus through a transmission line of resistance R_c and inductance L_c is used. In the selected model the following assumptions are made:

- The effects of the amortisseur are neglected.
- The resistance of the stator winding is neglected.
- The terms $\dot{\lambda}_d, \dot{\lambda}_q$ in the stator and load voltage equations are neglected compared with the terms of speed voltage $\omega\lambda_d, \omega\lambda_q$.
- The terms $\omega\lambda$ in the stator and load voltage equations are supposed to be approximately similar to $\omega_R\lambda$.
- It is supposed a balanced system without saturation effects.

Then, the equations of the system are given by:

$$\begin{aligned} K_3\tau'_{d0}\dot{E}'_{q\Delta} + E'_{q\Delta} &= K_3E_{FD\Delta} - K_3K_4\delta_\Delta \\ T_{e\Delta} &= K_1\delta_\Delta + K_2E'_{q\Delta} \\ V_{t\Delta} &= K_5\delta_\Delta + K_6E'_{q\Delta} \\ \tau_j\dot{\omega}_\Delta &= T_{m\Delta} - T_{e\Delta} \\ \dot{\delta}_\Delta &= \omega_\Delta \end{aligned} \quad (1)$$

By eliminating $V_{t\Delta}$ and $T_{e\Delta}$ of (1) it is obtained:

$$\begin{aligned} \dot{E}'_{q\Delta} &= -(1/K_3\tau'_{d0})E'_{q\Delta} - (K_4/\tau'_{d0})\delta_\Delta + (1/\tau'_{d0})E_{FD\Delta} \\ \dot{\omega}_\Delta &= -(K_2/\tau_j)E'_{q\Delta} - (K_1/\tau_j)\delta_\Delta + (1/\tau_j)T_{m\Delta} \\ \dot{\delta}_\Delta &= \omega_\Delta \end{aligned} \quad (2)$$

Taking the state variables $E'_{q\Delta}$, ω_Δ and δ_Δ , the input signals as $E_{FD\Delta}$ and $T_{m\Delta}$. Equation (2) is written in state-space (3). In figure 1 the block diagram (Anderson, 1993) shown describes the synchronous machine connected to an infinite bus through a transmission line. In this diagram the subscript Δ was omitted for convenience.

$$\dot{x} = \begin{bmatrix} -\frac{1}{K_3\tau'_{d0}} & 0 & -\frac{K_4}{\tau'_{d0}} \\ -\frac{K_2}{\tau_j} & 0 & -\frac{K_1}{\tau_j} \\ 0 & 1 & 0 \end{bmatrix} x + \begin{bmatrix} 1/\tau'_{d0} & 0 \\ 0 & 1/\tau_j \\ 0 & 0 \end{bmatrix} u \quad (3)$$

$$y = \begin{bmatrix} 0 & 0 & 1 \\ K_6 & 0 & K_5 \end{bmatrix} x$$

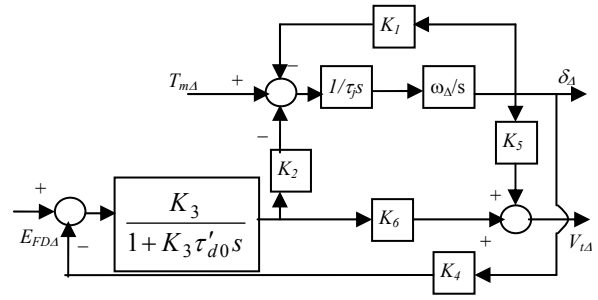

Figure 1: Block diagram of the simplified linear model of a synchronous machine

Assuming $\omega_R = 377$ rad/s, $R_c = 0.02$ pu (per unit), $L_c = 0.40$ pu, $V_a = 1$ pu, $V = 0.828$ pu, $\cos(\phi) = 0.85$, $x_d = 1.7$ pu, $x_q = 1.64$ pu, $x'_d = 0.245$ pu, the parameters of the system are presented in Table 1.

Table 1: Constant and parameters of synchronous machine model

Constant and parameters	
$K_1 = 0.7598$	$K_5 = -0.0409$
$K_2 = 1.2578$	$K_6 = 0.4971$
$K_3 = 0.3072$	$\tau'_{d0} = 5.6$
$K_4 = 1.7124$	$\tau_j = 1658.8$

3 EXPERIMENTAL PROCEDURE

3.1 Decoupling of the variables

Firstly, K is calculated according to the control law (4) to obtain a stable system. Subsequently a decoupling net is designed. By using (4), the matrixes N_i and M are determined, describing the system in equation (5). This tool uses a decoupling net that converts the MIMO system problem in a number of SISO system problems.

$$\hat{A} = (A - BK) \quad (4)$$

$$\dot{x} = (A - BK - NiM)x + BNiv \quad (5)$$

$$y = Cx$$

The system can be written as equation (6).

$$\begin{bmatrix} \dot{x} \\ \dot{x}_c \end{bmatrix} = \begin{bmatrix} A - B \cdot K - Ni \cdot M & B \cdot Ni \cdot C_c \\ -B_c \cdot H \cdot C & A_c \end{bmatrix} \begin{bmatrix} x \\ x_c \end{bmatrix} + \begin{bmatrix} 0 \\ B_c \end{bmatrix} r \quad (6)$$

$$y = [C \ 0] \begin{bmatrix} x \\ x_c \end{bmatrix}$$

With the controlled variable being

decoupled, it is possible to design a SISO controller for each one.

In this work the main objective is to introduce a hybrid controller for the load variable. To control the voltage variable a PD like fuzzy controller is used.

3.2 Design of the PID controller

In figure 2 the diagram of the multivariable control is shown.

The PID controller was adjusted by using the Ziegler-Nichols tuning rules method and then the system responses satisfactorily to a step input. The values obtained to adjust the controller are shown in table 2.

Table 2: Value of the PID controller constant obtained with the Ziegler-Nichols method.

Kp_{ZN}	Ki_{ZN}	Kd_{ZN}
0,0004	1,0E-9	0,02

3.3 PD like fuzzy controller

The fuzzy controller was designed using trapezoidal membership functions. The universe of discourse consists of five fuzzy values:

1. PL: positive large.
2. PS: positive small.
3. ZE: zero.
4. NS: negative small.
5. NL: negative large.

Figure 2 shows the universe of discourse and the membership functions.

Furthermore, the following control rules (Li and Lau, 1988) were used with the previously presented membership functions:

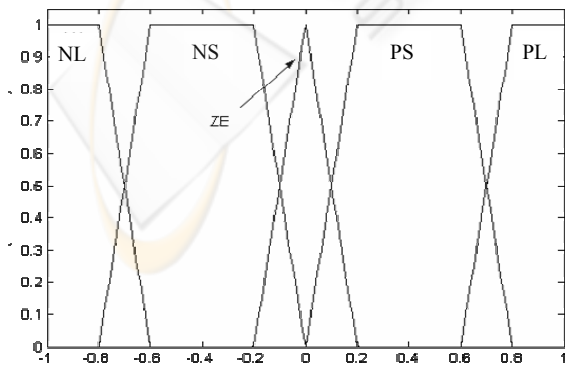

Figure 2: Universe of discourse and membership function

1. if e' is PL and $\Delta e'$ is any, then u is PL.
2. if e' is PS and $\Delta e'$ is PS or ZE, then u is PS.
3. if e' is ZE and $\Delta e'$ is PS, then u is ZE.
4. if e' is ZE and $\Delta e'$ is NS, then u is NS.
5. if e' is NS and $\Delta e'$ is NS, then u is NS.
6. if e' is PL and $\Delta e'$ is any, then u is NL.

The fuzzy controller uses Mamdani (max-min) defuzzification. The controller works on the load variable of the system. Figure 3 shows the block diagram of the overall control system. It can be noticed that the decoupling artifact for the variables has been included in the system model. It can be also observed that a PD like fuzzy controller is used for the load and for the voltage.

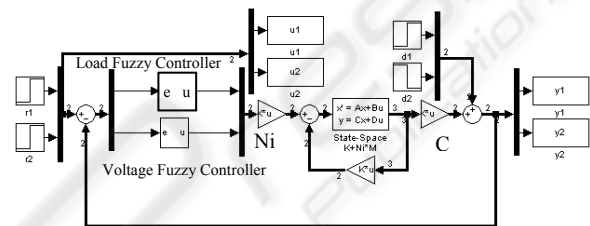

Figure 3: Decoupled control system with a fuzzy controller for the load and for the voltage

3.4 The adaptive fuzzy rules

To adjust the employed fuzzy controller an adaptive fuzzy law is implemented, the membership functions are showed in figure 4.

Then to adjust the parameter Kp of the fuzzy controller the following relations are used:

$$Kp = FKp \cdot Kp_{ZN}$$

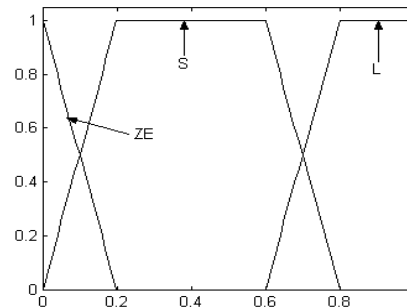

Figure 4: Universe of discourse and membership function for the adaptive law

- The rules used are:
- If $|e|$ is L then FKp is 1.7
 - If $|e|$ is S then FKp is 1.7
 - If $|e|$ is ZE then FKp is 1

Figure 5 shows the inference system that allows generating the variations of FKp.

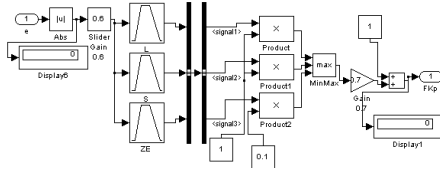

Figure 5: System to generate variations of FKp

3.5 Adaptive Fuzzy Sliding Control

The methodology used here is proposed in (Li and Gatland, 1997) to improve the fuzzy controller. The switching line is formed by a hierarchical method given by:

$$\begin{aligned} \sigma_1 &= \lambda e + \dot{e} \\ \sigma_2 &= \lambda \sigma_1 + \dot{\sigma}_1 \\ &\vdots \\ \sigma_{n-1} &= \lambda \sigma_{n-2} + \dot{\sigma}_{n-2} \end{aligned} \tag{7}$$

In this case the output of the sliding surface variable is used as the input of the adaptive controller.

3.6 Implanting the adaptive controller to the synchronous machine system

When all the necessary subsystems, such as the fuzzy controller, the PID controller are designed and the outlined scheme of control is defined, the following step is to integrate all these in the control system to solve the problem.

Figure 6 shows the block diagram of the system of final control system. It can be noticed that the action of fuzzy controller will work together to control the load.

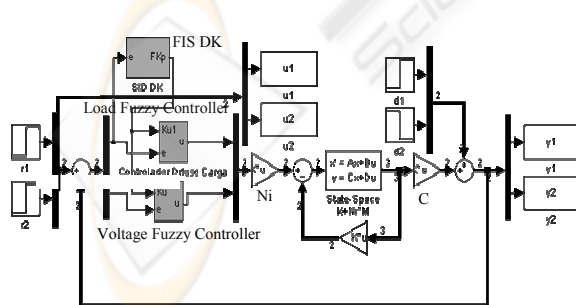

Figure 6: Adaptive Fuzzy Controller

4 RESULTS AND DISCUSSION

In this section simulations are presented and the analysis of the results obtained from the control scheme proposed in this work. With this system simulations were carried out having a step input signal of 0.8 p.u. of magnitude at 100 s after the start point. The responses of the system with and without the fuzzy variable structure controller and other control strategies are presented.

4.1 Comparison of the adaptive fuzzy controller with other controllers

The results of the tests carried out with the Adaptive PD Like Fuzzy Controller are shown in different detail in figures 7, 8 and 9. It can be observed in figure 7 that the PID controllers have a larger settling time than the PD controllers. The PID controllers reach a stationary state between 100 s and 450 s after the input reference is introduced. On the other hand, the PD Like Fuzzy controllers achieves smaller rise time to about 50 s after the input. Among the PID controllers, the fuzzy controller shows the best effectiveness. This controller is able to follow the reference with a delay of about 100 s without overshoot. The classic PID controllers present overshoot.

In figure 8 a more detail the comparison among the controllers is shown. In this detail, it can be observed that the PD like fuzzy controller has a better response-time and settling time than all the PID controllers. Inclusive, they show zero steady state error. Also, the PD like fuzzy controllers stabilize in about 20 s, while the quickest for the PID controllers is 100 s. The fast behavior in the PD on top of the PID is due to the predominant action of the proportional and derivative factors of the controllers; they react to the changes in the error.

Making another comparison between these controllers, in figure 9 the PD like fuzzy controller and adaptive PD like fuzzy controller can be compared. In this figure an even faster settling time is reached: less than 20 s, without overshoot. In general, the adaptive controller is better than the PD like fuzzy controller. In the transitory response the adaptive fuzzy controller is able to overcome in 5 s the fuzzy controller. This figure also shows that the adaptive fuzzy controller responds even quicker than all the controllers previously mentioned.

With these results obtained, the theory of variable structure control was applied to compare it with the best controllers obtained.

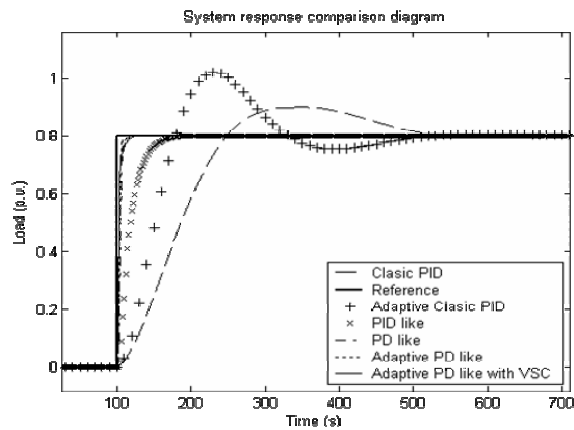

Figure 7: System response comparison

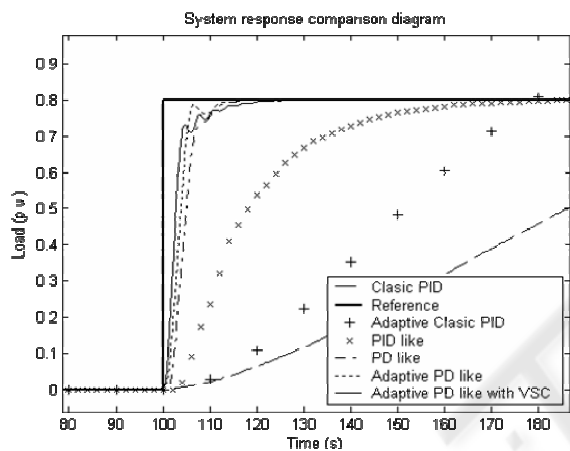

Figure 8: Detail of the transitory system responses

like fuzzy controller responses also presented to establish comparison points illustrate the effectiveness of the system with VSC.

In can be noticed in figure 11 that the settling time of the controller with VSC is about 25 s while the other controllers is less than 20 s. From this point of view, the PD controllers without VSC are superior. Looking at the controllers' response, that with the VSC reacts more quickly than the others, achieving an advantage of a little more than 1 s. Then, according to the results, by applying these controllers in particular to this system, it can be appreciated a compromise between the speed response and the settling times of these controllers.

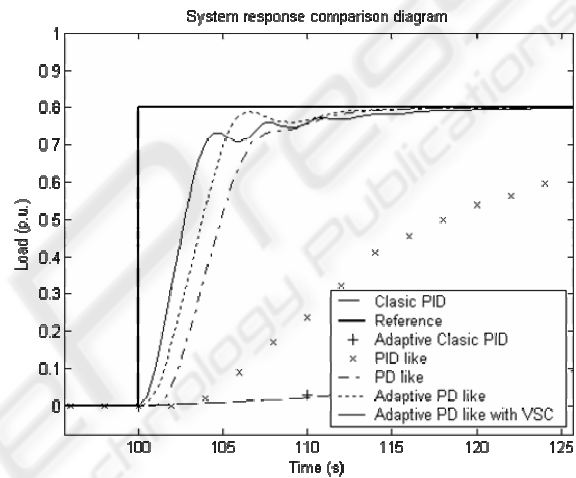

Figure 9: Adaptive Controller and others

4.2 The adaptive PD like fuzzy controller with and without the VSC and their comparison with the PD like fuzzy controller

The results obtained in this section are essential in this work. In figure 10 the application of the theory of variable structure control (VSC) to an adaptive fuzzy controller is showed. In this figure, the PD

The action of the fuzzy controller is remarkable. The behavior of the system corresponds to the requirements of the designer, allowing interesting results for the transient. It can be observed that the action of system with any of the fuzzy controller suppresses any overshoot produced by using a classical PID controller, overcoming its effectiveness during the transient response.

In Figure 12 the response of the system with load change is showed and Figure 13 presents a detail

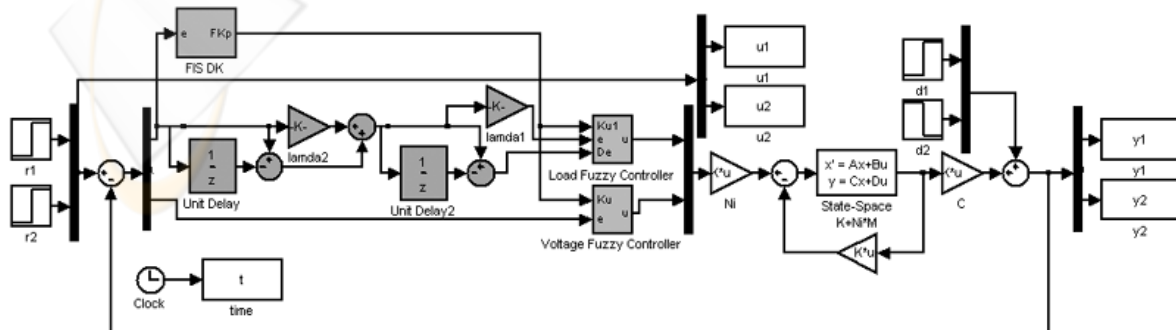

Figure 10: Fuzzy VSC Scheme

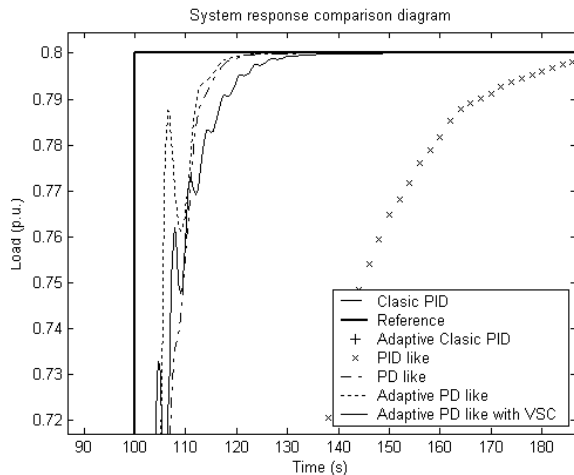

Figure 11: Adaptive and VSC Fuzzy Controller comparison

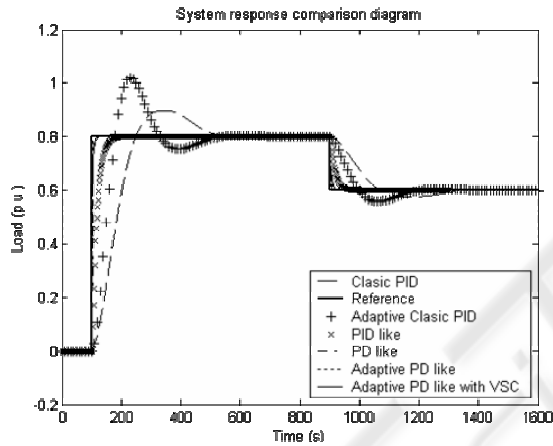

Figure 12: Response of the system to load change for different control schemes

5 CONCLUSIONS

The model used for the synchronous machine can be decoupled allowing the separate study for each one of its controlled variables. The response of the system with the outlined fuzzy adaptive controller is superior to any other scheme used to control the synchronous machine. The combination of both techniques also allows a spectrum of possibilities to perform control actions on the controlled variable of the system. The number of rules and the universe of discourse used to define the fuzzy inference system is very simple and small which allow an easy implementation. The use of oriented object programming helps to make the controller design a more simple process. The design of these control

schemes with or without the VSC for the system enhances the capacities and potentials of achieving physical realizations that show a high level of autonomy and flexibility. The use of a fuzzy technique to control synchronous machine is recommended due the satisfactory results obtained in these experiences.

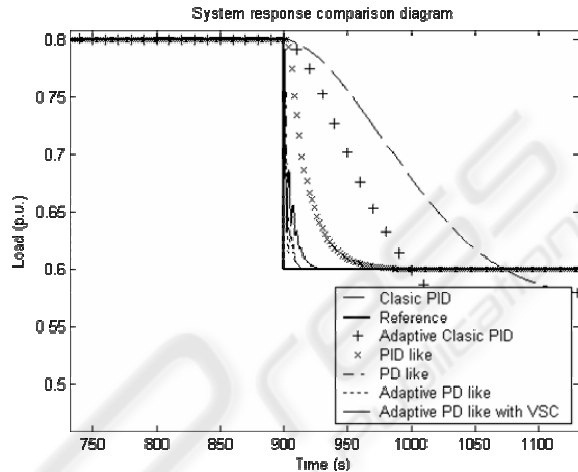

Figure 13: Detail of the load change response of the system for different schemes

REFERENCES

Anderson, P., 1993. *Power System Control and Stability*. IEEE Power Systems Engineering Series.

Huang, S-J and Lin, W-Ch., 2003. Adaptive Fuzzy Controller with Sliding Surface for Vehicle Suspension Control. *IEEE Transaction on Fuzzy Systeme, Vol. 11, No. 4 August*.

Jang J-S., C-T. Sun and Mizutani, E., 1997. *Neuro-Fuzzy and Soft Computing*, Prentice Hall.

Li, H.X. and Gatland, H.B., 1997. Fuzzy Variable Structure Control. *IEEE Transactions on system, man, and cybernetics Part B. Vol. 27, No. 2, April*.

Li, Y.F. and Lau, C.C., 1988. Development of Fuzzy Algorithms for Servo Systems. *IEEE International Conference on Robotics and Automation, Philadelphia, Pennsylvania, April, 24- 29, 1988*.

Takagi T. and Sugeno M., 1985. Fuzzy Identification of Systems and its applications to Modelling Control. *IEEE Trans. on System, man and Cybernetics, V. SMC-15, pp. 116-132*.

Vidyasagar M., 1993. *Nonlinear System Analysis*. Prentice Hall Inc.

Yager R.R. and Filev D.P., 1994. *Essentials of Fuzzy Modeling and Control*. Wiley & Son, Inc.