

A REFERENCE ARCHITECTURE FOR MANAGING VARIABILITY AMONG TELEOPERATED SERVICE ROBOTS

Francisco Ortiz, Juan Ángel Pastor, Diego Alonso, Fernando Losilla and Esther de Jódar
Systems and Electronics Engineering Division, Technical University of Cartagena, Campus Muralla del Mar, s/n,
Cartagena, Spain

Keywords: Architectures, Fieldbus, robot control, teleoperation.

Abstract: Teleoperated robots are used to perform hazardous tasks that human operators cannot carry out. The purpose of this paper is to present a new architecture (ACROSET) for the development of these systems that takes into account the current advances in robotic architectures while adopting the component-oriented approach. ACROSET provides a common framework for developing this kind of robotized systems and for integrating intelligent components. The architecture is currently being used, tested and improved in the development of a family of robots, teleoperated cranes and vehicles which perform environmentally friendly cleaning of ship-hull surfaces (the EFTCoR project).

1 INTRODUCTION

Teleoperated mechanisms, such as robots, vehicles and tools (or a combination of these), perform inspection and maintenance tasks in hostile environments. The capabilities and the areas of application of these systems grow from day to day, but so does their complexity. As stated in (Coste, 2000), one way of dealing with this complexity is *to use architectural frameworks and tools that embody well defined concepts to enable effective realization of systems to meet high level goals.*

There have been numerous efforts to provide developers with architectural frameworks of this kind (Bruyninckx, 2002), (Nesnas, 2003), (Scholl, 2001). The objects of this paper are twofold: to present an architectural approach to the development of control units for these systems and to present an example of its use in the development of a real system. The architectural approach, ACROSET, is based on the latest advances in robotic architectures and adopts a component-oriented approach. ACROSET offers a way to re-use the same components in very different systems by separating the components from their interaction patterns. It also provides a common framework for developing robotized systems with very different behaviours and for integrating intelligent components. The

architecture is currently being used, tested and improved in the development of a family of teleoperated cranes and vehicles for environmentally friendly cleaning of ship hull surfaces (the EFTCoR project).

This paper is structured in six sections. Section two presents the characteristics of the application domain which determine the architectural drivers that have guided the design of ACROSET. The third section presents a brief description of the EFTCoR missions and mechanisms. Sections four and five respectively describe the ACROSET architecture and two of its instantiations. Finally, section six summarizes the conclusions and future plans.

2 THE TELEOPERATION DOMAIN

Teleoperated systems cover a broad range of mechanisms that carry out inspection and maintenance activities in hostile environments. Usually these systems perform a small number of highly specialized tasks. Such specialization implies:

- High variability of functionality and physical characteristics.
- Different combinations of vehicles, manipulators and tools.

- A large variety of execution infrastructures, including different kinds of processors, communication links and HMIs.
- A large variety of sensors and actuators.
- Different kinds of control algorithms, from very simple reactive actions to extremely complex navigation strategies.
- Different degrees of autonomy, from operator-driven systems to semi-autonomous robots.

And yet, despite all these differences, teleoperated systems are normally very similar from a logical point of view, having many common requirements in their definition and many common components, either logical or physical, in their implementation. These similarities allow the designer to define a common architecture for all such systems. To be able to use such architecture for all developments is extremely useful. It allows rapid development of systems and reuse of a large variety of components, with concomitant savings in time and money. Considering the differences among the systems mentioned above, it is clear that the main objective of the architecture is to deal with such variability. To achieve that, there are a number of points that must be considered:

- Very different systems should be able to use the same components. This implies that the architecture should make a clear distinction between components and interaction patterns.
- The component implementations could be software or hardware, probably including COTS (Commercial off the Shelf).
- It should be possible to derive concrete architectures for operator-driven systems and autonomous intelligent systems.

3 THE EFTCOR SYSTEM

A good example in teleoperation domain could be the EFTCoR project (EFTCoR, 2002), which addresses the development of a family of robots whose mission is to retrieve and confine the paint, oxide and adherences from ship hulls. The EFTCoR system is part of the European Industry's current effort to introduce environmental friendly ship maintenance. Although the EFTCoR family of robots are specifically designed for ship hull maintenance, they still present a broad spectrum of behaviours and degrees of complexity and as such provide an

excellent test bench for a reference architecture. The sources of variability in EFTCoR are the following:

- Hull dimensions and shapes differ widely.
- Different areas of any given hull impose very different working conditions for robots.
- Working areas differ in different shipyards or even within the same shipyard.
- There are operational differences between cleaning small, discrete areas (spotting) and full blasting.
- Other hull maintenance operations can be included, such as fresh water washing and painting before and after coating removal.

The tremendous variety described above generates very different problems, and these require different robotic systems, each suited to a given type of shipyard, hull, part of the hull, operation, etc.

It may then be impossible to design a single robotic system to perform all tasks, but it is still possible to design the different robotic systems in such a way that as many components as possible are shared. EFTCoR's robotized systems consist of a primary positioning system capable of covering large hull areas and a secondary positioning system mounted on primary system that can position a tool over a relatively small area (4 to 16 m²). Different combinations of primary/secondary/tool have been considered and tested (see Figure 1).

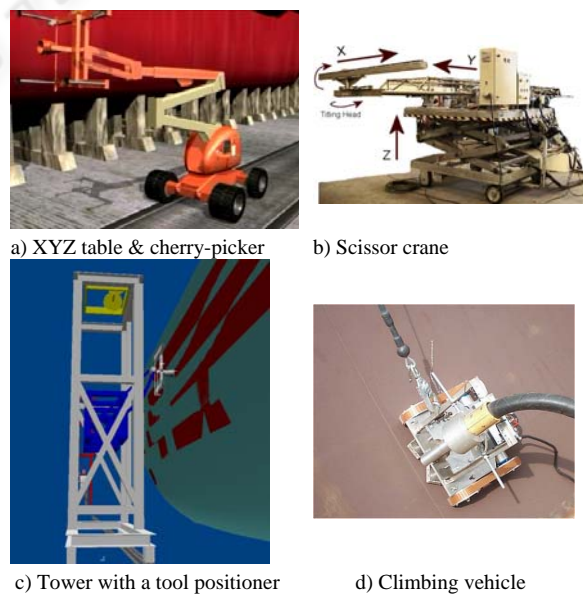

Figure 1: Different solutions for grit blasting

Finally, it is important to stress that the EFTCoR is an industrial project and as such should

use components that are common in industrial facilities (PLCs rather than work-stations, field buses rather LANs, etc.)

4 THE REFERENCE ARCHITECTURE

ACROSET (*Arquitectura de Control para Robots de Servicio Teleoperados**) is a reference architecture for teleoperated service robot control units. The architecture emerged from previous works at the DSIE (*División de Sistemas e Ingeniería Electrónica, Universidad de Cartagena, Spain*) (Iborra, 2003), (Ortiz, 2000), and is currently being used in the EFTCoR project. ACROSET takes account of the sources of variability explained in sections 2 and 3 and the architectural drivers developed to deal with them.

ACROSET is supposed to make very different systems to use the same components, and therefore the first step was to define the rules and common infrastructure that would allow components to be assembled or connected. To that end, the concepts of components, ports and connectors were adopted as defined in (Hofmeister, 2000). The connector concept allows components' functionality to be separated from their interaction patterns, because such patterns contained within the connectors. The notation followed to describe the components, ports and connectors is inspired by the 4 views of Hofmeister (Hofmeister, 2000) and ROOM (Selic, 1994), which extend the UML notation with stereotyped classes and special symbols (see subsection 4.1.)

The subsystems defined by ACROSET are shown in Fig. 2. The first subsystem of the architecture, which should be present in every system, is the *Coordination, Control and Abstraction Subsystem (CCAS)*. The CCAS abstracts and encapsulates the functionality of the physical devices of the system. The CCAS is composed of *virtual* components which can be implemented in either software or hardware, even considering COTS. This subsystem breaks down into several components distributed in hierarchical layers (see section 4.1).

To deal with operator-driven and semi-autonomous systems, an *Intelligence Subsystem (IS)* is proposed. In this way, autonomous behaviours

can be added if necessary, interacting with the functionality offered by the CCAS as another user. This separation of intelligence and functionality enhances the modifiability and adaptability of the system to new missions and behaviours. The intelligence can be combined with the operator commands depending on the application or mode of operation. A *User Interaction Subsystem (UIS)* is proposed to interpret, combine and arbitrate between orders that may come simultaneously from different users of the system's functionality (CCAS), since the system does not concern itself with the source of the order.

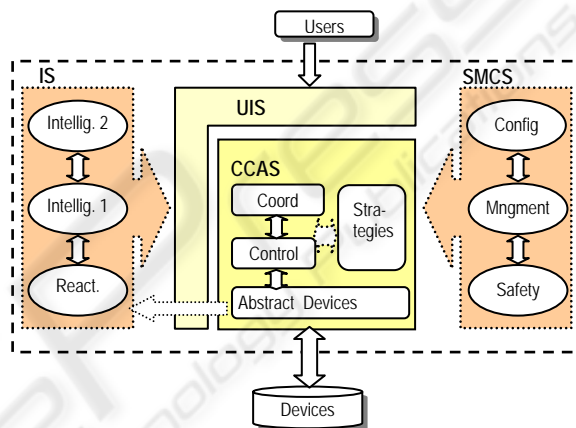

Figure 2: An overview of ACROSET subsystems

Other important aspects besides the functionality or the intelligence of the system include the safety and the possibilities of configuration and management of the application. To differentiate between functionality *per se* and the monitoring of such functionality, a *Safety, Management and Configuration Subsystem (SMCS)* is proposed. Another function of this subsystem is to manage and configure the initialization of the application.

4.1 The Coordination, Control and Abstraction Subsystem (CCAS)

The CCAS of a given system comprises components that are defined in four layers of granularity:

- Layer 1: Abstract the characteristics of atomic components, such as sensors and actuators.
- Layer 2: Simple Unit Controllers (SUCs).
- Layer 3: Mechanisms controllers (MUCs).
- Layer 4: Robot controllers (RUCs).

The simplest components modelled by the architecture are the sensors and actuators, which are

* Control Architecture for Teleoperated Service Robots.

defined at the lowest architectural level. The SUC components model the control over the actuators (Figure 3). For example, there will be SUCs defined to control every joint of a given mechanism. The SUC generates commands for the actuator according to:

- The orders that it receives from another component (through the **SUC_Control** port).
- The information it receives from the sensors.
- Its installed control policy.

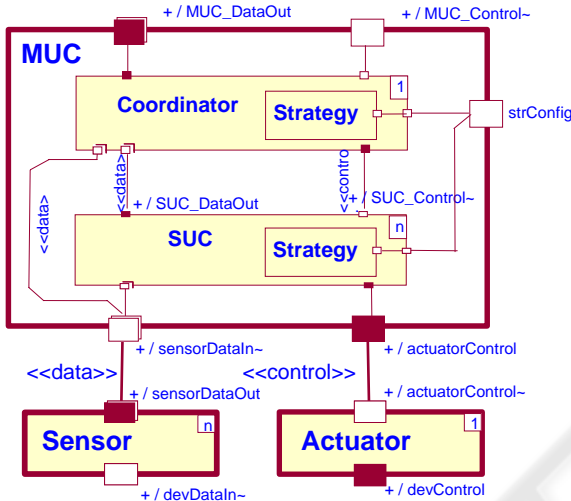

Figure 3: MUC and SUC. 1 actuator - N sensors

The control policy is an interchangeable part of the SUC. For example, the **ControlStrategy** of a given joint may be a traditional control (PID) or may be changed for a fuzzy logic strategy. The SUCs usually need to accomplish hard real time requirements and are generally implemented in hardware. Where they are implemented in software they impose severe real time constraints on operating systems and platforms.

Defined at the third level of granularity is the Mechanism Unit Controller (MUC). The MUC component models the control over a whole mechanism (vehicle, manipulator or end effector). As Fig. 4 shows, the MUC is a logical entity composed of:

- An aggregation of SUCs.
- A Coordinator responsible for coordinating SUC actions according to the commands and information that it receives.
- Its installed coordination strategy.

The coordination strategy is an interchangeable part of the SUC component. For example, the **CoordinationStrategy** of a given manipulator may

be a particular solution for its inverse kinematics, the coordinator strategy for a given vehicle could be a particular navigation strategy, etc.

Although the architecture defines the MUCs as relational aggregates, they can actually become components (hard or soft) when the architecture is instantiated to develop a concrete system. Whether or not the interfaces of the inner SUCs are directly accessible is a decision for the architecture instantiation. In fact, although MUCs may be implemented in either hardware or software, they are very commonly commercial motion control cards that constrain the range of possible commands to its internal components. COTS elements limit the flexibility of the approach, in the sense that they do not always provide direct access to their inner sub-components or to their inner state.

Finally, at the fourth level, the architecture defines the RUC (Robot Unit Controller) component. The RUC component models the control over a whole robot, for example a robot composed of a vehicle with an arm and several interchangeable tools. As Figure 4 shows, the RUCs are an aggregation of MUCs and a global coordinator that generates the commands for the MUCs and coordinates their actions, according to the orders and the information that it receives and its installed coordination strategy.

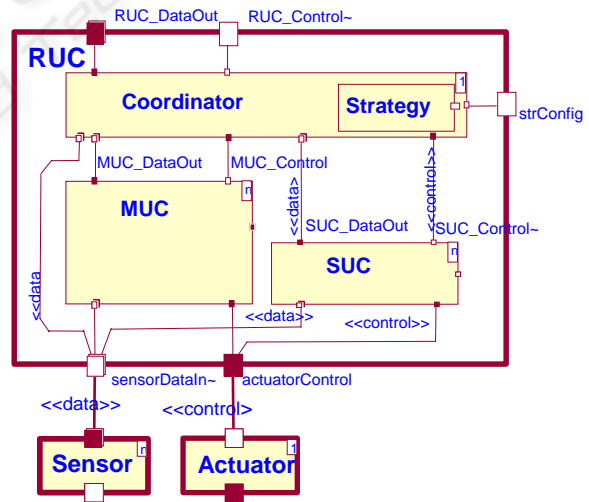

Figure 4: RUC: Robot Unit Controller.

This strategy is an interchangeable part of the RUC. For example, the **CoordinationStrategy** of a robot composed of a vehicle with a manipulator could be a generalised kinematics solution that contemplates the possibility of moving the vehicle to

reach a given target. Like the MUCs, the RUCs are logical components that can become physical components depending on the concrete instantiation. In general, the RUC is quite a complex component that comprises hardware and software components and can expose a wide variety of interfaces depending on the complexity of the controlled system.

4.2 The Intelligence Subsystem (IS)

It is beyond the scope of this paper to give a detailed explanation of the IS, but we do offer some considerations at this point. The CCAS is well suited to operator-driven systems and systems where the reactive or autonomous behaviour responds to simple rules that can be added to controllers and coordinators. However, there are systems where the autonomous behaviour is anything but simple. In such cases, the *intelligent component* needs to integrate more information and access more functionality than what is embedded in a given component. The approach adopted here is to *superimpose* “*intelligent*” autonomous behaviour and operator-driven behaviour, and to provide the means of integrating both and resolving the potential conflicts by means of “*arbitration*” components which merge commands from several sources following different strategies and provide a unique command to the goal component. This approach does not entail any change in the components defined so far, but it does entail new sources of commands for them. Such “*arbitrators*” permits the goal components not to change although new sources are introduced.

5 ACROSET INSTANTIATION ON EFTCOR

The ACROSET architecture is being implemented on a real system, the family of robots in EFTCoR project. This section presents two instantiations of the architecture. As we will see, they have been chosen to illustrate the suitability of ACROSET for defining the concrete control architectures of two very different systems.

5.1 ACROSET in teleoperated XYZ table

The first instantiation of ACROSET is used for developing the control unit of a system composed of

a XYZ table (Fig. 1. a, c) holding the cleaning tool. This tool consists of an enclosed nozzle for making the blasting and recovering of residues. The system can be driven by a human operator and it can also perform some autonomous tasks. The XYZ table is supported by a commercial crane whose control is not considered in this instantiation.

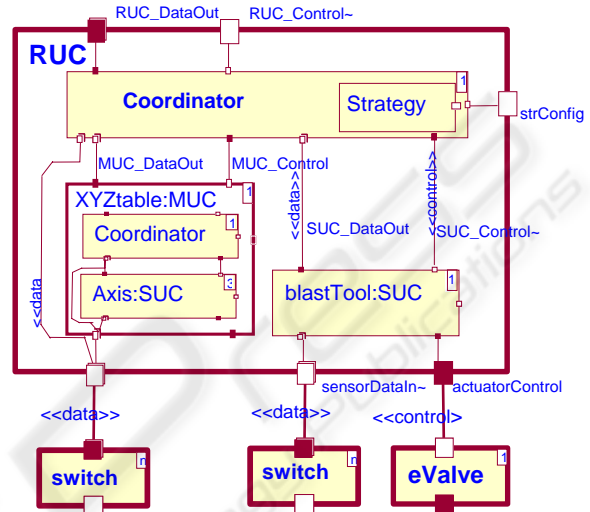

Figure 5: Components of CCAS in XYZ table Control Unit.

The components integrated in the *Coordination, Control and Abstraction Subsystem (CCAS)* are shown in Figure 5. The RUC encloses all the functionality required to drive the XYZ table and the tool. The MUC and SUC included in the RUC control the XYZ table and the blasting tool respectively. The MUC coordinates three SUCs, one for each axis of the table. In this case the actuators are logically placed inside the SUCs and are accessed through the SUC interface. This is imposed by the system’s hardware architecture. In this case, COTS hardware controllers have been used to control the electrical motors of the XYZ table. Therefore, the hardware that is abstracted is not merely an engine but a complete axis controller. The actuator is hidden to the control unit and the SUC is thus a “*hardware abstraction component*” contained in a MUC. The SUCs that control the axes therefore have a software part and a hardware part. The RUC and the MUC are implemented entirely in software.

Following ACROSET, the intelligence of the system, like the fault and configuration management, is located outside the CCAS. The two are respectively included in the *Intelligence*

Subsystem (IS) and the *SMCS*, as shown in Figure 2. The *real intelligence* included in the *IS* varies considerably from system to system. In this particular case the *IS* interprets a pre-programmed sequence of motions and orders that have been generated by a vision system. The vision system is an external system, running on a PC, that analyses the surface to be cleaned, generates trajectories and delivers them to the *IS*, which in turn delivers them to the *UIS* and supervises their execution. A human operator can supervise the movements commanded by the vision subsystem and take corrective action by means of a joystick. An arbitrator situated in the *UIS* determines which is controlling the system at all times (note that the *CCAS* only receives orders from one channel coming from the *UIS*).

In response to the special industrial requirements of the EFTCoR project, the system has been implemented using a PLC[†] SIMATIC S7-300 (4 in figure 6) and a Field-Bus (PROFIBUS-DP, 2 in figure 6). The development environment is “STEP 7” from SIEMENS (SIEMATIC, 2002). Each SUC, MUC and RUC has been translated to PLC *Function Blocks* (FBs) (SIEMATIC, 2002). With the option of FB instantiation in SIMATIC S7-300 series, it is possible to program the PLC with a philosophy that is close to the object-oriented paradigm (each FB acts as a class which can be instantiated). For instance, a generic axis controller (SUC) has been defined to create three instances, the controllers (SUCs) for the X, Y and Z axes, each with their particular features. In this case, the SUCs implement interfaces to the hardware controllers (drivers) of the electrical motors (6 and 7 in figure 6)

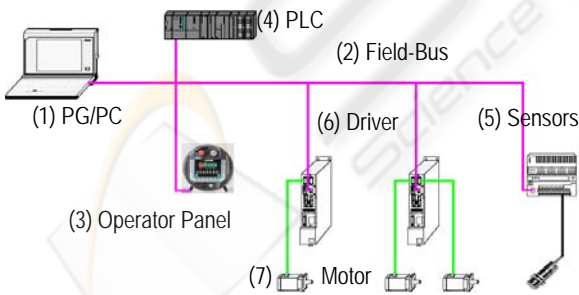

Figure 6: Hardware architecture

The PLC and Field-Bus based solution adopted is based entirely on standard industrial equipment (SIEMENS devices interconnected via PROFIBUS-DP), which facilitates the integrability,

[†] Programmable Logic Controller

interoperability and maintainability of the complete system.

5.2 ACROSET for a teleoperated vehicle

The second instantiation is a caterpillar vehicle capable of scaling a hull thanks to permanent magnets (Figure 1- d), carrying a manipulator that holds a cleaning tool. Like the previous system, the vehicle can be driven by a human operator and also performs some autonomous tasks, such as obstacle avoidance and simple path execution.

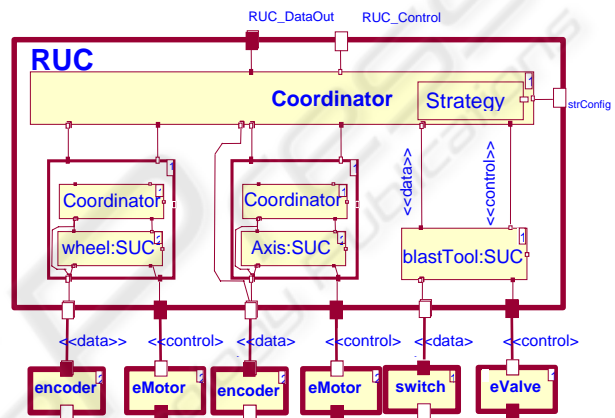

Figure 7: Components of CCAS in climbing vehicle

Figure 7 shows the CCAS instantiated for the control unit in this system. As can be seen in the figure, two different MUCs have been implemented: one to control the vehicle and another to control the manipulator. The first contains one SUC to control each of the electrical motors that move the vehicle. On the other side, the manipulator MUC coordinates two SUCs, one for each manipulator axis. The vehicle uses the same tool as the XYZ table, so this SUC is conceptually the same, but it has been implemented in a different way.

Unlike the previous case, the motion controllers are not implemented by means of COTS hardware components, but by means of Ada packages that implement the interfaces defined by ACROSET. In this case the implementation allows direct access to the hardware without mediation by any SUC. However, as in the previous case, the application has been designed to allow either a human operator or an external system to access the CCAS functionality through the *UIS*. Two different intelligent behaviours have been added to the *IS*: obstacle avoidance and path execution. The components of the *IS* that implement these behaviours obtain the information they need from the vehicle sensors and

generate commands to the CCAS. Integration between these commands and the operator commands is resolved by an arbitrator in the UIS.

The execution platform is an on-board embedded PC. The PC/104 bus (PC104, 2004) is a widely used industrial standard with many advantages, such as vibration-resistance, modularity, mechanical robustness, small form factor (96 x 115 mm), low power consumption, etc. Moreover, it can be easily extended with boards that provide the kind of functions needed by robots (digital and analogue I/O, motion control, PCMCIA expansion, etc). The chosen OS is RTLinux (Barabanov, 1997), with which makes it is possible to have a real-time application running while retaining all the power of a Linux distribution (though with some restrictions) underneath.

6 CONCLUSIONS AND FUTURE WORKS

The use of a common architecture for a domain or family of systems allows rapid developments and the reuse of components. This paper has presented a common architectural framework for the development of teleoperated service robots control units (ACROSET), and also two application examples in the context of the EFTCoR project that show the ability of ACROSET to cope with the needs and requirements of very different systems. The separation of the conventional functionality of the systems (CCAS) from the intelligent behaviours greatly facilitates the addition of new functionalities and the maintenance of applications. The main drawback is the lack of language support for expressing a component-oriented style of programming.

ACKNOWLEDGMENTS

The DSIE wishes to thank the Spanish Government (CICYT) and the Regional Government of Murcia (Seneca Programmes) for their support: TIC2003-07804-C05-02 and PB/5/FS/02.

REFERENCES

Barabanov M.. "A Linux-based Real-Time Operating System". Master Thesis, New Mexico Institute of

- Mining and Technology, Socorro, New Mexico, June 1997.
- Bruyninckx, H., Koninckx, B. and Soetens, P., "A Software Framework for Advanced Motion Control", Dpt. of Mechanical Engineering, K.U. Leuven. OROCOS project inside EURON. Belgium. February 2002. Retrieved October 12, 2003 from <http://www.orocos.org>
- Coste-Manière, E. and Simmons, R., "Architecture, the Backbone of Robotic System", *Proc. of the 2000 IEEE International Conference on Robotics & Automation*, San Francisco, April 2000.
- EFTCoR - Environmental Friendly and Cost-Effective Technology for Coating Removal. V Framework Program GROWTH G3RD-CT-00794. 2002-2005
- Gamma E., Helm R., Johnson R., Vlissides J., "Design Patterns: Elements of Reusable Object Oriented Software", *Addison Wesley*, Reading Mass. 1995.
- Hofmeister, C. Nord, R., Soni, D., "Applied Software Architecture", *Addison-Wesley*. ISBN 0-201-32571-3. USA. January 2000.
- Iborra, A. Pastor, J.A., Álvarez, B. C. Fernández and Fernández-Meroño J. M., "Robots in Radioactive Environments", *IEEE Robotics and Automation Magazine*, vol. 10, no. 4, pp. 12-22, December 2003.
- Nesnas, I. et al, "CLARAty: An Architecture for Reusable Robotic Software", Jet Propulsion Laboratory, NASA, Carnegie Mellon University, March 2003.
- Ortiz, F.J. et al "GOYA: A teleoperated system for blasting applied to ships maintenance". *3rd International Conference on Climbing and Walking Robots*. CLAWAR'2000. October, 2000.
- Scholl, K.U. Albiez, J. and Gassmann, B. "MCA - An Expandable Modular Controller Architecture", Karlsruhe University, Germany, 2001.
- Selic, B. Gullekson G., Ward P.T., "Real-Time Object-Oriented Modeling" (ROOM). *John Wiley and Sons*, New York. 1994.
- SIMATIC - Working with STEP 7 5.2. ref. 6ES7810-4CA06-8BA0. SIEMENS manuals. 2002.
- PC104. Retrieved May 1, 2004, from <http://www.pc104.org>